



DIRECTIONS FOR USING ZDZ ENGINES

(Please READ this carefully and become FAMILIAR with these instructions before using the engine)

ZDZ two-stroke gasoline engines are intended for large models and offer excellent power to weight ratio. Before being shipped from the factory, each ZDZ engine is tested and pre-adjusted. As a result, there is rarely need for the user to make much in the way of adjustments. In general, they require only some minor carburettor adjustments that take into consideration the propellers and mufflers being used.

BASIC SPECIFICATION

All ZDZ engines are equipped with diaphragm carburetors made by Walbro or similar diaphragm carburetor. (These carburetors are adjusted with two mixture screws that are marked with the letter "H" (for the adjustment of High speed) and by the letter "L" (for the adjustment of idle and the acceleration from idle to full throttle). Basic adjustment - Both mixture adjustment screws are opened 540 degrees (1 ½ turns) from the fully closed (stop) position.) For more detailed setup read below.

ZDZ engines are equipped with commonly sized special SKF ball bearings. The piston con rod is equipped with SKF needle bearings. All ZDZ engines are equipped with NGK CM-6 spark plugs(or similar) since 2013.

FUEL

We recommend the use of a good quality super (98+ Octane) gasoline and a semisynthetic or synthetic oil (specifically formulated for high performance air cooled two stroke engines - API TC, JASO FD, ISO-L-EGD/OEM, TISI) in 40:1 ratio. Make sure that the mixture is filtered before use. Avoid to use felt-filters inside the tanks which can make fuel intake to the carburettor difficult.

EXHAUST SYSTEM

We recommend you to order and use suitable muffler from following producers:

JMB - mufflers and in-cowl mufflers <http://www.jmb-brecka.com>

MTW – mufflers <http://mtw-daempfer.de/en>

Many other muffler suppliers are worldwide and you can get their contacts from your local dealer.

We do not recommend to make experiments with own design of mufflers, badly designed mufflers can cause overheating of engine and damage the engine which will cancel warranty.

How to mount exhaust system depends on its type. Most manufacturers recommend the proper mounting method for their mufflers.

COOLING OF ENGINE- BAFFLINGS

One of the most important aspect of an engines installation is its cooling. Be sure that ratio between the area for air intake into the cowl and air outlet from cowl of the model is at least 1:3 which means the size of intake is at least three times smaller than the size of outlet vent.

Directional air baffles are HIGHLY recommended. Please see attached photo. The air should be directed to and through the cylinder/s by baffles. Very important is to target the airflow to the center of the cylinder/s and heads. Baffles can be made of plywood, fibreglas or sheet metal. Overheated engines are NOT covered by the ZDZ warranty. EXAMPLE OF WELL MADE BAFFLINGS



ENGINE MOUNT

The engine can be mounted directly to firewall or to a engine box which is conical changing its shape gradually from engine to a firewall. Non-symmetric solution of box helps to decrease vibration level. IN ANY CASE soft rubber spacers or soft silent blocks should not be used. This solution can cause damage of the engine and bearing by providing even higher vibration level.

Engine box if made of multiple layer plywood should be 7mm thick and when finished can be covered by one ply of fiber and epoxy to make it stronger. This size works well for engines up to 180B2RV-J. For bigger engine plywood should be even thicker.

SEE SOME EXAMPLES OF ENGINE MOUNT

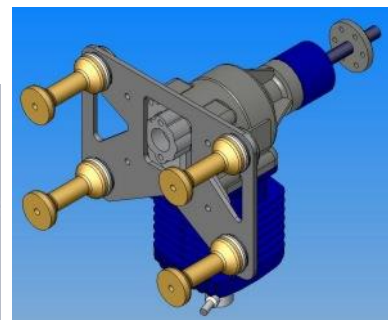
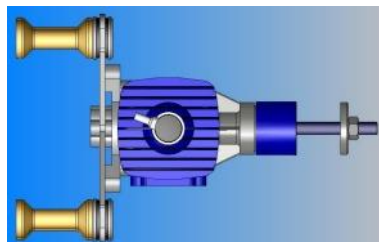
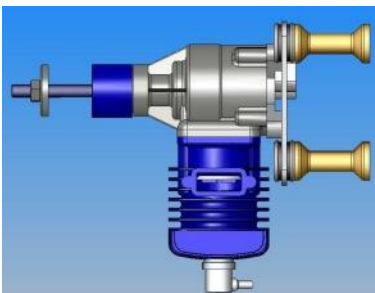



MORE examples of correct mounting you can see on www.zdz.eu, <https://www.facebook.com/zdzrc/> and their galleries.

INSTALLATION OF THE PROPELLERS

The propeller you use is primarily defined by the purpose of use. The only important aspect of propeller installation is to have it statically and dynamically perfectly balanced and very well tightened on engines hub before the engine.

ATTENTION: whenever you use a wooden propeller you have to keep in mind that when new it can be slightly pressed by installation and running and its tightening has to be controlled after each engine run for the first several hours.

INSTALLATION OF THE IGNITION SENSOR

ZDZ engines with new line of electronic ignition have a sign for positioning of sensor on the side of front crankcase as shown on the picture. This sign shows basic setup of ignition and has to be aligned with the sensorholder edge as shown on the picture.



ADJUSTMENT OF THE ENGINE

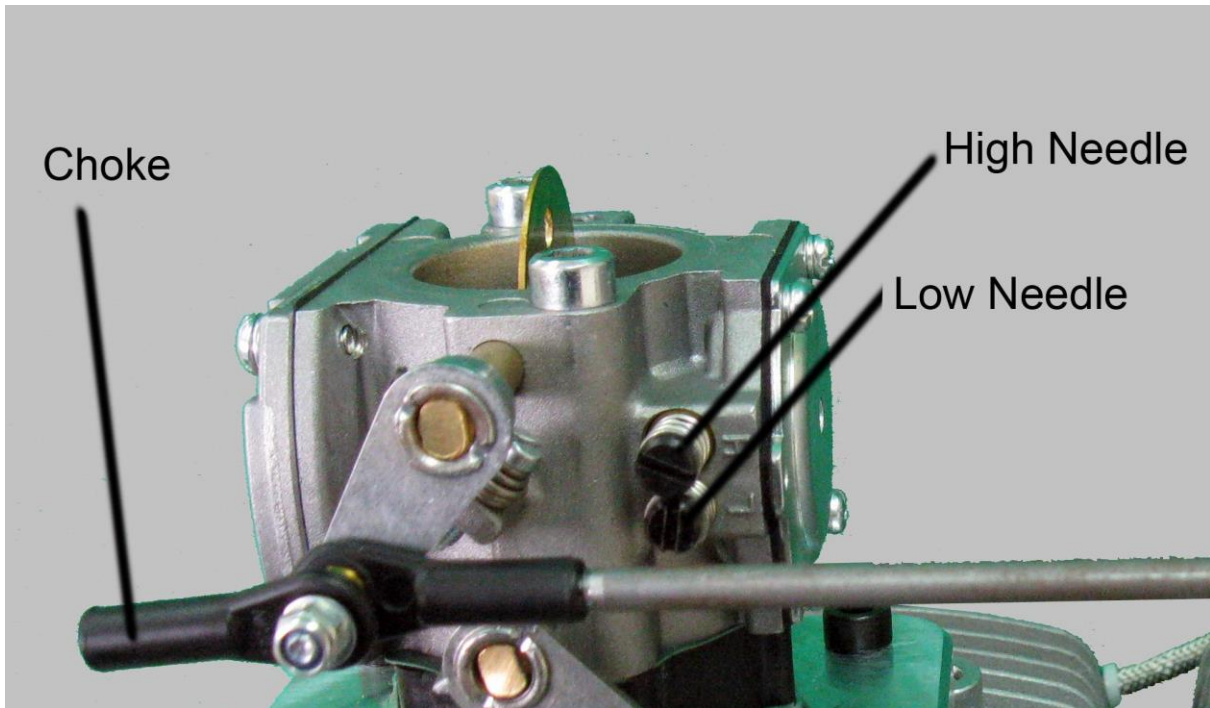

After fitting the engine into the model and after installation of the ignition, you can start the engine. (Note: Installation of the ignition must be in accordance with the manufacturer's directions.)

1. Switch on the ignition, close the choke and suck gas into the intake of the carburetor by flipping the propeller over counter-clockwise. As soon as the engine is wet, it should start to run, but will stop due to the rich mixture. Next, open the choke and start the engine again by flipping as before.

Note: The time it takes to draw gas into the carburetor depends on the length of the fuel feed to the carburetor.

Safety Notes: In the event that you adjust the engine in your model, be sure to switch on the receiver and the transmitter before starting it. It is NECESSARY if the transmitter is set to "idle".

WARNING: IF THE THROTTLE IS SET TO ANY SPEED ABOVE AN IDLE, THE MODEL MAY MOVE IMMEDIATELY WHEN THE ENGINE STARTS!. AT ALL TIMES, SECURE THE MODEL AND/OR HAVE A HELPER WHO HOLDS THE MODEL SECURELY WHILE STARTING THE ENGINE. FOR LIGHTWEIGHT MODELS BE CAREFUL BECAUSE, EVEN AT IDLE, THE MODEL CAN MOVE TOWARDS YOU..

2. Let the engine run for about 30-60 seconds (depends on the outside temperature) on idle to allow it to warm up and then advance the throttle slowly.

3. Keeping well away from the propeller (behind it), adjust the engine to maximum RPM with the mixture adjustment screw marked with an "H" When ready, turn the needle 90degrees to the left to make engine rich enough for IN-FLIGHT max RPMs which are higher than on the ground. Measure the RPMs by Epower RPM meter or any other optical RPM meter.

4. Reduce the throttle and set the idle mixture with the mixture adjustment screw marked "L". Then use the same screw to adjust for a smooth transition from idle to full throttle. A well-adjusted engine will have a stable idle and will not surge up and down after the throttle is closed.

5. If it **accelerates** slightly when the throttle is closed, the engine is too lean. **SOLUTION:** Open the mixture screw "L" a little and check the idle again.

6. On the other hand, if it **slows down** after the throttle is closed, the engine is too rich. **SOLUTION:** In this case, close the mixture screw „L“ a little and check the idle again.

7. If you give your WARMED engine full throttle and it has a „delayed response“ with acceleration it is too lean **SOLUTION:** Open the mixture screw "L" a little and check the idle again.

8. If you give your WARMED engine full throttle and response is burbling and slow transition engine is too rich. **SOLUTION:** In this case, close the mixture screw „L“ a little and check the idle again.

When adjusting the carburettor, it is strictly prohibited to run the engine. It **MUST** be stopped during carburetor setup to avoid any contact between you and rotating propeller which can cause serious injury or death. .

Note: If you change propeller diameter and/or pitch, the engine may need to be re-adjusted.

Note: To reduce noise, install an engine intake filter and use a suitable expansion muffler.

HERE ARE SOME RECOMMENDATION FOR BASIC NEEDLE SETUP BEFORE YOU START TO TUNE IT FOR YOUR CONFIGURATION

Type of engine	„L“-Needle	„H“-Needle
----------------	------------	------------

(Numbers shown declare number of revolution from zero tightened position of the needle)

56RV-J	1 ¼ - 1 ½	1
60RV	1 1/5	1 ¼
90RV-J	1 ¼ -1 1/5	1 ¼ -2
112B2RV-J champion	1 ½	1 1/5
180B2RV-J champion	1 ¼	¾ -1
195B2RV-J champion	1 ¼	¾ -1
210B2RV-J	1 ½	1 ½
250B2RV-J	1 ½	1 ½ -1 ¾
210R2-J INLINE	1 ¼ -1 1/5	1 ¼ -2
250R2-J INLINE	1 ½	1 4/5 -2
360B4-J	1 ¼	¾ - 1
420B4-J	1 ½	1 ¼
500B4-J	1 ½ - 1 ¾	1 ¼

BREAK-IN PERIOD

For break-in use more lubricated fuel (35:1) . You can fly during the BREAK-IN period with your model but it is strictly prohibited to run the engine on full throttle for longer period than 20seconds for first 3 hours of run.

Perfect COOLING is one of the most important parts of run and break-in too. SEE COOLING paragraph to be sure if your solution is correct.

PLEASE BE SURE THAT ALL FOLLOWING POINTS ARE OK WITH YOUR ENGINE INSTALLATION BEFORE YOU ARE GOING TO FLY:

AT HOME BEFORE YOU LEAVE TO AIRFIELD

- Engine is mounted correctly
- Air flow for the engine is made as described/shown in instructions and cooling is right
- Exhaust system and mainly headers are cooled correctly and good enough too
- Propeller used is well drilled and correctly BALANCED
- Propeller size is correct as recommended by ZDZ
- Propeller screws are tight and central nut was re-tighten as last one
- Correct switch (e.g. SR-SWITCH) is used for your ignition
- No additional filter or valve is installed between tank and carburettor
- Fuel lines are tight and correctly mounted
- Fuel mixture is prepared according to these instructions
- Spark plugs are tightened correctly (10-15Nm are required to have it properly tightened)
- Spark plug caps are mounted correctly onto engine
- Ignition is safely mounted and can not move
- Ignition cables are well mounted and covered by additional rubber where go through the cowl or fuselage

ON THE AIRFIELD BEFORE THE FLIGHT „PRE-FLIGHT CHECK“

- If you feel sick, and/or your reactions are slower than normally for any reason, DO NOT USE the engine to avoid its damage or your injury.
- Secure your model properly BEFORE YOU START IT by second person holding its wings or tail or by strong wire or rope safely connected to the tail of model and to the ground anchor or any other stable and heavy point.
- Keep all people except your technician behind the model or even better behind the security net
- Do not wear loose clothing, neckties, or neck/back straps for your radio. It can get caught by rotating propeller and cause serious injury
- ALWAYS use eye protection when starting the engine.
- BE CAREFUL and do not put your fingers into the space of rotating propeller and do not stay in front of it when engine runs
- Carburettor is adjusted and engine tested and warmed „ON THE GROUND“ before flight.
- Fuel was filtered before given to the model tank

WARRANTY

ZDZ ENGINES s.r.o. guarantees its engines for a period of 24 months, provided any damage is not caused by tampering with the engine, by the use of unsuitable fuels or by the crash of a model.

Company warrants its ZDZ engines only against defects in material or workmanship under normal use. This limited warranty is effective for the period defined at the time of purchase by ZDZ. The warranty is fully transferable to new owners. This limited warranty does not cover damage resulting from improper installation, use of unapproved mufflers, accident, disaster, misuse, abuse or unauthorized modifications/repair.

THE ENGINES PRODUCED BY ZDZ MODELMOTOR s.r.o. ARE NOT TOYS. IMPROPER USE can cause serious injury or death! BE SURE YOU ARE familiar with this entire instruction manual before usage of ZDZ engine. ALL its paragraphs are important and you should REALLY READ AND LEARN them to avoid any misuse of your ZDZ engine and possible troubles as well as warranty cancellation.

THE ENGINES PRODUCED BY ZDZ ENGINES, s.r.o. ARE NOT INTENDED FOR POWERING ANY MANNED MACHINERY OR MANNED MEANS OF TRANSPORT. THE COMPANY IS NOT RESPONSIBLE FOR ANY DAMAGE TO PERSONS OR PROPERTY IF THE ENGINES ARE USED FOR THIS PURPOSE.

THE ZDZ ENGINES ARE INTENDED ONLY FOR POWERING RADIO CONTROLLED MODELS, MAINLY MODEL AIRCRAFT AND UNMANNED AERIAL VEHICLES IN WHICH NO PEOPLE ARE TRANSPORTED.

ZDZ ENGINES, s.r.o.

Ing. et Ing. Michal Janoušek

Tel: 00420 778 002 077, email: michal.janousek@zdz.eu, www.zdz.eu,
www.facebook.com/zdzrc rev. 04092017